

## GREENMAX™ COMPACTOR POSEIDON C200



> Screw Compression Technology enables continuous output at a ratio of 8:1, high density and security, low utility consumption.



> Reputable & High quality components make the machine reliable and durable



> Water draining function squeezes out the liquid to the water collection tray.



> Water collection tray is made of acid-resistant stainless steel to withstand the low PH in many liquids.



> SIEMENS control system guarantees easy and simple operation.



> CE approved and comply with UL/CSA standards

### > APPLICABLE MATERIAL:

|                      | PET BOTTLES   | ALUMINUM CANS   | PE/PP FILM  | BEVERAGE CARTONS   | YOGURT CUPS   |
|----------------------|---|---|---|--|---|
| <b>MATERIAL</b>      |  |  |  |  |  |
| <b>FEED IN/ HOUR</b> | 7000pcs/0.5L<br>3000pcs/1.5L<br>2300pcs/2.0L<br>1700pcs/2.5L                        | 7000pcs/0.33L   | ----  | 4500pcs/0.25L  | 12000pcs/0.1L   |
| <b>OUTPUT/ HOUR</b>  | appr. 200kg<br>440 lbs  | appr. 200kg<br>440 lbs  | appr. 400-450kg<br>880-990 lbs  | appr. 200kg<br>440 lbs   | appr. 120kg<br>260 lbs  |

> DIMENSIONS

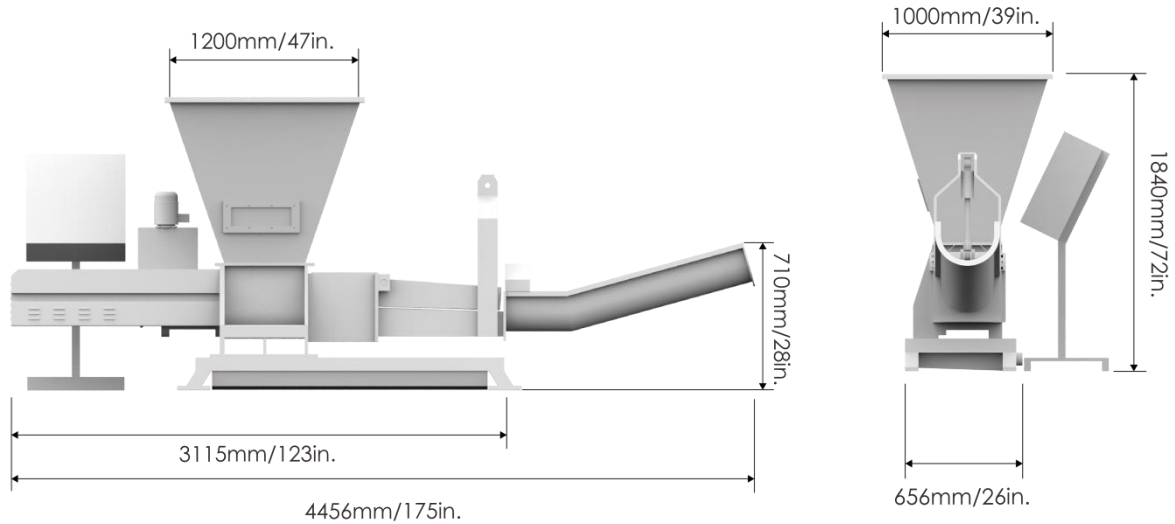

> TECHNICAL DATA

| ITEM                    | P-C200   |
|-------------------------|--|
| Total Power Consumption | 8.05 kw / 10.8 hp  |
| Screw Rotation Speed    | 30rad / min  |
| Screw Reduction ratio   | 50:1   |
| Bottle Volume Reduction | 10:1   |
| Compressed PET Density  | 250 kg/m <sup>3</sup> / 510 lbs/cubic yard   |
| Feed Hopper Door        | 1200*1000*1840 (l/w/h) mm / 47.2*39.4*72.4 (l/w/h) in.   |
| Dimensions              | 4456*1000*1840 (l/w/h) mm / 175.4*39.4*72.4 (l/w/h) in.  |
| Shipping Dimensions     | Main part: 3215*1100*2040 (l/w/h) mm / 126.6*43.3*80.3 (l/w/h) in.<br>Output chute: 1441*550*600 (l/w/h) mm / 56.7*21.7*23.6 (l/w/h) in. |
| Weight                  | 1,350 kg / 2,976 lbs   |